



**SHAY
MURTAGH**



Technical Manual

Box Culverts

First Edition

Introduction

For over forty years Shay Murtagh Precast has been at the forefront of the civil engineering industry. We are industry specialists in the design and manufacture of precast and pre-stressed concrete products and our products include provisions to the utility, rail, infrastructure and commercial sectors.

We value each project individually and provide a flexible design service to adapt to specific client requirements. Our working partners demand the highest quality in product, reliability in service and confidence in team, all of which we deliver categorically. This successful basis has led us to work on a wide range of projects throughout the UK and Ireland with leading main contractors and clients.

Shay Murtagh Precast is one of the largest producers of precast box culverts in both the UK and Ireland. Our modern mechanised box culvert manufacturing facilities allow us to produce culverts in a wide range of standard unit sizes. Shay Murtagh Precast is not limited to standard culvert sizes and our flexible production lines, experienced engineers and knowledgeable technical team can readily provide for larger units to meet the most unique of project specific designs.

This is the First Edition of our Box Culvert Technical Manual. The manual is intended to illustrate the variety of applications and significant benefits of using precast concrete box culverts and provides an overview of their structural design and detailing. The manual includes section thickness tables for a wide range of culvert sizes that will greatly assist with the preliminary design, detailing and costing of culverts. The manual identifies and provides details for the available structural variations of precast concrete box culverts that are manufactured by Shay Murtagh Precast. Finally, the manual presents additional structural components and details that may be used in conjunction with culverts.

We believe that this manual combined with our expert technical team will be an invaluable asset enabling you to successfully choose the best and most economical solution to meet your projects requirements.

For consultation with our Design Team please contact:

technical@shaymurtagh.co.uk or

UK Tel: 0844 202 0263

IRL Tel: +353 44 9374108 / 9374149



Contents: Structural Types

Standard Box Culvert

Typical Applications:

Bridging watercourses, pedestrian access, carrying services.

Advantages:

Easily installed.
Range of additional features.
Structurally efficient.

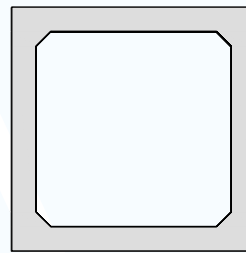

pg 9-11

Standard UAN

Typical Applications:

Bridging watercourses, pedestrian access, vehicle access.

Advantages:

Enables large culverts to be precast and transported.

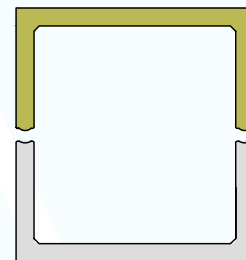

pg 12-14

Standard Portal

Typical Applications:

Bridging watercourses, pedestrian access, carrying services.

Advantages:

Leaves stream bed undisturbed.
Structurally efficient.

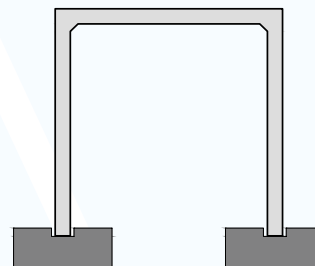

pg 15-17

Jointed Portal

Typical Applications:

Medium span bridging, vehicle access, rail bridges.

Advantages:

Leaves stream bed undisturbed.
Long spans at low cost.

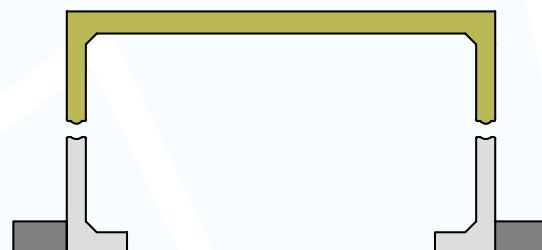

pg 18

Skewed & Splayed Box Culverts

Typical Applications:

Allows a box culvert line to change direction.

Advantages:

Facilitates flexibility in the culvert path.

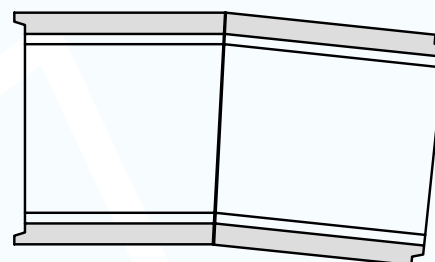

pg 18

Contents: Structural Types

Standard U-Section

Typical Applications:
Open channels, wingwalls at the ends of box culverts.

Advantages:
Easily installed, structurally efficient.

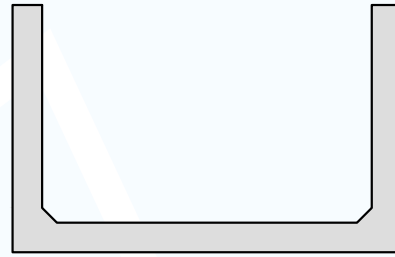

pg 18

U-Section with Lid

Typical Applications:
Units where access from above is required.

Advantages:
Allows much longer individual units to be produced.
Allows easier access.
Facilitates easy cleaning or placing of stream bed material.

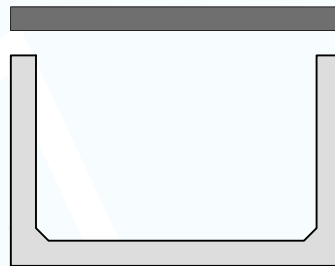

pg 18

Attenuation Tank

Typical Applications:
Flood mitigation systems.
Water or other liquid storage.

Advantages:
Large storage volumes at low cost.

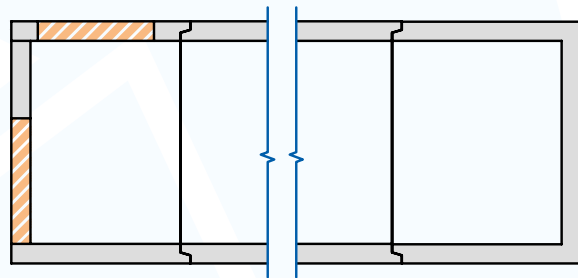

pg 19

Double Cell Culvert

Typical Applications:
Large cumulative spans.

Advantages:
Optimal structural efficiency.

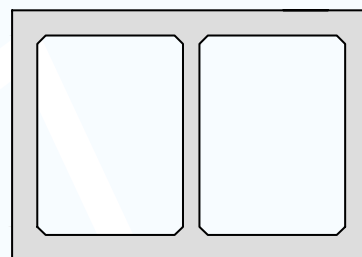

pg 19



Contents: **Additional Components and Features**

Dry Weather Flow (D.W.F.) Channel

Typical Applications:

Accommodates self cleansing requirements.
Accommodates low flow conditions.

Advantages:

Reduced maintenance requirements.

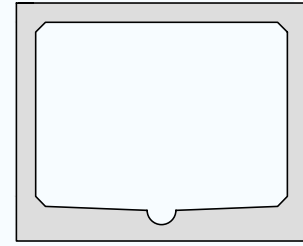

pg 20

Mammal Shelf

Typical Applications:

Accommodates requirement to provide small mammal passage

Advantages:

Quicker installation and more economical than special onsite provisions.

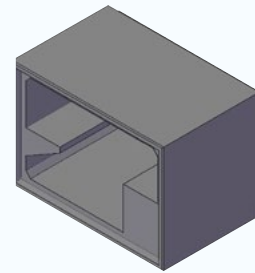

pg 20

Fish Baffles

Typical Applications:

Accommodates requirement to provide fish passage

Advantages:

Quicker installation and more economical than special onsite provisions.

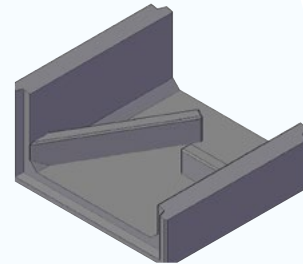

pg 21

Head Beams and Wing Walls

Typical Applications:

Retains the embankments at the ends of a culvert line.

Advantages:

Prevents embankment erosion and loss of backfill behind the culverts.

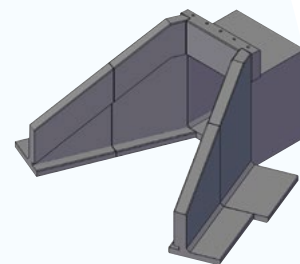

pg 22

Drainage Outfall

Typical Applications:

Retains the embankment and prevents scour at the ends of a pipe line.

Advantages:

Easily installed.
Eliminates the need for in-situ scour protection.

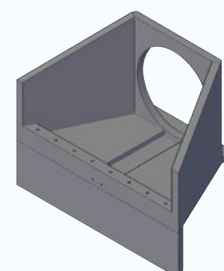

pg 22

Box Culverts

Applications

- Watercourse bridging
- Watercourse diversions
- Road crossings
- Pedestrian and vehicle subways
- Attenuation tanks
- Service tunnels
- Ducting
- Shafts
- Mammal crossings
- Pipe replacements
- Sea outfalls



Benefits of Box Culverts from Shay Murtagh Precast

- **Flexible Range**
An extensive range of culvert section sizes are available with the ability to add multiple cells, splayed ends, and options to assist flow characteristics using sloped V inverts and half round channels.
- **Ease of Installation**
Box culverts can easily be installed in single or multiple runs.
- **Durability and Long Service Life**
A design life of over 120 years is easily achieved with minimum maintenance.
- **Bespoke Designs**
Our in-house technical team can design and detail culverts offering a range of sizes and features to meet any job specific requirements.
- **Proven Production Process**
The production process is compliant with BS EN9001, BS EN 14001 and CE Marking requirements. Our culverts are designed and manufactured to relevant Eurocodes and associated National Annexes, BS and PD standards. The production process is compliant with BS EN9001 & certified to I.S. EN 14844 Precast Concrete Products – Box Culverts, CE Marking requirements.

Box Culvert Fundamentals

The dimensions of a box culvert unit are always given as Internal Width x Internal Height (Dim 'A' x Dim 'B').

Culvert units of any size can be produced in lengths up to 2m (Dim 'C'), however longer units can be manufactured in some special cases.

The **section thickness** is the uniform thickness of both walls and slabs and is principally determined by the culvert dimensions, depth of fill and type of live loading carried by the culvert. The section thickness of units manufactured by Shay Murtagh Precast range from 200mm to 750mm.

Fillets at the internal corners are typically 100mm x 100mm or 150mm x 150mm.

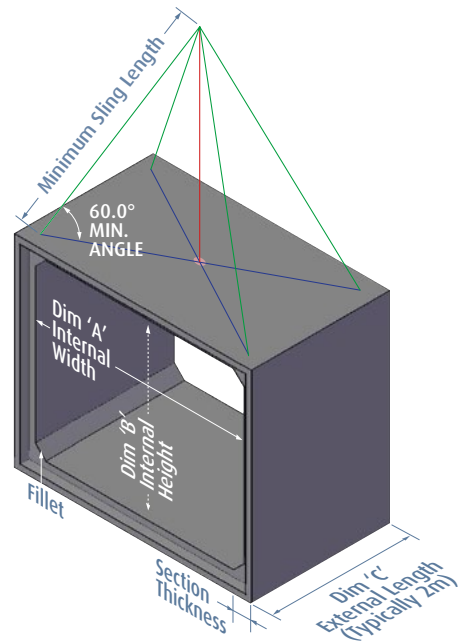

Typical Box Culvert Unit

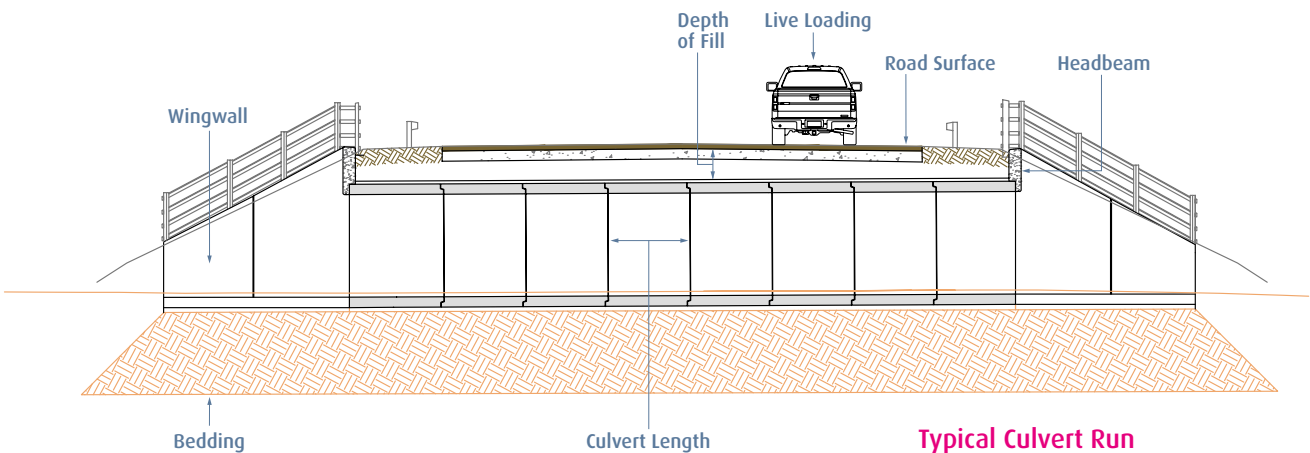

Typical Culvert Run

When designing a culvert both the minimum and maximum **depth of fill** must be assessed. If the culvert carries vehicle loadings, then the minimum and maximum depth of fill below the carriageway & verge should be specified. The depth of fill is taken to the top face of the culvert.

The **bedding** is the founding material on which the culverts are laid. Bedding is intended to ensure uniform support under the full width and length of the box culvert.

The **head beams** and **wingwalls** function to retain the embankment at the ends of the culvert line and prevent the loss of backfill to the culverts and the subsequent blockage of the culvert, deterioration of the road or other surface passing over the culvert.

Design Criteria

This Box Culvert Technical Manual serves to assist the design engineer, client and installer with a reference document and tool for the selection of the appropriate box culvert section size given a range of loading conditions and depths of fill material.

The manual also provides an appreciation of the variety of additional available options and ancillary products associated with box culverts.



Hydraulic Design

The design of box culverts includes two distinct phases: hydraulic design and structural design. This document focuses on the structural design of culvert sections that have internal dimensions based on an earlier hydraulic design.

Structural Design and Detailing

Shay Murtagh Precast carries out the detailed structural design of the vast majority of the precast concrete box culverts and other similar structures outlined in this Manual. The detailed design is carried out in accordance with the relevant parts and associated National Annexes of Eurocode 0, Eurocode 1, Eurocode 2 and Eurocode 7 in addition to PD 6694-1, PD 6687-2 and BS 8500-1. Shay Murtagh Precast adheres to the requirements of BS EN 14844:2006 Precast concrete Products – Box Culverts dealing with aspects of design, manufacture and installation. This document in turn cross references BS EN 13369:2001 Common Rules for Precast Concrete Products.

Our experienced team of design engineers and technicians provide a flexible, comprehensive and optimised design and detailing service enabling the client's design and specification criteria to be captured and communicated in a clear and user friendly manner.

Stages in Box Culvert Design

The typical stages involved in the design of a precast concrete box culvert are as follows:

<p>Assess Purpose of Culvert</p>	<ul style="list-style-type: none"> • Hydraulic requirements (internal dimensions) • Culvert usage • Length required • Wing wall extent and layout
<p>Assess Site Conditions</p>	<ul style="list-style-type: none"> • Depths of fill (minimum and maximum) • Live loading conditions • Exposure classes to BS 8500 and BS EN 206 • Culvert formation ground conditions and bearing capacity • Lifting weight constraints
<p>Structural Design</p>	<ul style="list-style-type: none"> • Contact Shay Murtagh Precast with the above information • Shay Murtagh Precast carries out the detailed structural design of the box culvert and associated structural elements
<p>Approval of Design</p>	<ul style="list-style-type: none"> • Keep in contact with Shay Murtagh Precast and provide design feedback • Once satisfied, approve the design for manufacture • Make preparations for the delivery and installation of the box culvert

It is recommended to contact Shay Murtagh Precast early on in the design process in order to achieve a cost effective design which can meet all of the project requirements and deadlines. Early contact with Shay Murtagh Precast provides our clients with access to the extensive experience and advice offered by the technical team and ensures that all relevant information regarding design, project changes, special site requirements and delivery dates are addressed early in the design process. This approach facilitates an efficient design process and serves to eliminate potential project delays.

Live Loadings and Fill Depth

Particular attention is drawn to the need to provide Shay Murtagh Precast with the minimum and maximum depth of fill above the culvert and indicate the type of live loading carried by the culvert. Live loading may be specified as standard vehicle loading (i.e. Eurocode 1 compatible LM1, LM2 and LM3 highway loading), pedestrian or other uniform loading, rail loading, or specific vehicle loading that is not covered in Eurocode 1. The minimum and maximum depth of fill below the road should be specified if vehicular loading is relevant. See tables 1-7 overleaf for how the depth of fill and type of live loading affects the required section thickness. It is recommended that the minimum fill depth should not be less than 600mm, however this is not always possible and such cases must be assessed on an individual basis.

Types of Structures

Standard Box Culvert

Typical Applications:

Bridging watercourses, pedestrian access, carrying services.

Advantages:

- Easily installed.
- Range of additional features.
- Structurally efficient.

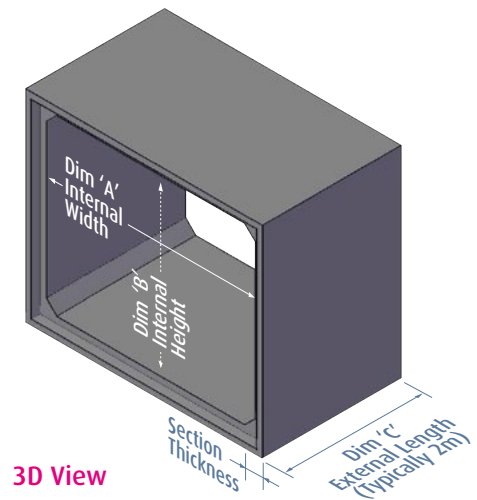

Max unit length (Dim 'C'): 2000mm is available for all unit sizes, however we can extend this to 2500mm for specific cases.

Section Thickness Tables for Standard Box Culverts

Tables 1 to 3 below indicate the recommended culvert section thicknesses for units that do NOT carry highway loading based on the depth of fill above the top of the culvert.

Table 1. NO HIGHWAY LOADING - LESS THAN 3000mm DEPTH OF FILL - SECTION THICKNESS (mm)

		INTERNAL WIDTH (m)											
		0.5	1.0	1.5	2.0	2.5	3.0	3.5	4.0	4.5	5.0	5.5	6.0
INTERNAL HEIGHT (m)	0.5		200	200	200	200	200	200	200	200	250	300	300
	1.0	200	200	200	200	200	200	200	200	200	250	300	300
	1.5	200	200	200	200	200	200	200	200	250	250	300	300
	2.0	200	200	200	200	200	200	200	200	250	250	300	350
	2.5	200	200	200	200	200	200	200	200	250	300	300	350
	3.0	200	200	200	200	200	200	200	250	250	300	300	350

Table 2. NO HIGHWAY LOADING – 3000mm TO 6000mm DEPTH OF FILL - SECTION THICKNESS (mm)

		INTERNAL WIDTH (m)											
		0.5	1.0	1.5	2.0	2.5	3.0	3.5	4.0	4.5	5.0	5.5	6.0
INTERNAL HEIGHT (m)	0.5		200	200	200	200	200	250	250	300	350	400	400
	1.0	200	200	200	200	200	200	250	300	300	350	400	400
	1.5	200	200	200	200	200	200	250	300	350	400	400	450
	2.0	200	200	200	200	200	250	250	300	350	400	400	450
	2.5	200	200	200	200	200	250	300	300	350	400	400	450
	3.0	200	200	200	200	200	250	300	350	400	400	UAN	UAN

Table 3. NO HIGHWAY LOADING – 6000mm TO 8000mm DEPTH OF FILL - SECTION THICKNESS (mm)

		INTERNAL WIDTH (m)											
		0.5	1.0	1.5	2.0	2.5	3.0	3.5	4.0	4.5	5.0	5.5	6.0
INTERNAL HEIGHT (m)	0.5		200	200	200	200	250	300	350	400	400	450	500
	1.0	200	200	200	200	200	250	300	350	400	400	450	550
	1.5	200	200	200	200	250	250	300	400	400	450	500	550
	2.0	200	200	200	200	250	300	350	400	400	450	500	600
	2.5	200	200	200	200	250	300	350	400	400	450	500	600
	3.0	200	200	200	200	250	300	350	400	400	UAN	UAN	UAN

Tables 4 to 6 below indicate the recommended culvert section thicknesses for units that carry highway loading based on the depth of fill above the top of the culvert.

Table 4. HIGHWAY LOADING - LESS THAN 600mm DEPTH OF FILL & SURFACING – SECTION THICKNESS (mm)

		INTERNAL WIDTH (m)											
		0.5	1.0	1.5	2.0	2.5	3.0	3.5	4.0	4.5	5.0	5.5	6.0
INTERNAL HEIGHT (m)	0.5		200	200	200	200	200	250	250	250	300	300	350
	1.0	200	200	200	200	200	200	250	250	250	300	300	350
	1.5	200	200	200	200	200	250	250	250	300	300	350	350
	2.0	200	200	200	200	200	250	250	300	300	300	350	350
	2.5	200	200	200	200	200	250	250	300	300	350	350	400
	3.0	200	200	200	200	250	250	300	300	300	350	350	400

Table 5. HIGHWAY LOADING – 600mm TO 3000mm DEPTH OF FILL & SURFACING - SECTION THICKNESS (mm)

		INTERNAL WIDTH (m)											
		0.5	1.0	1.5	2.0	2.5	3.0	3.5	4.0	4.5	5.0	5.5	6.0
INTERNAL HEIGHT (m)	0.5		200	200	200	200	200	200	250	250	300	350	400
	1.0	200	200	200	200	200	200	200	250	300	300	350	400
	1.5	200	200	200	200	200	200	250	250	300	350	350	400
	2.0	200	200	200	200	200	200	250	250	300	350	400	400
	2.5	200	200	200	200	200	200	250	300	300	350	400	400
	3.0	200	200	200	200	200	250	250	300	350	350	400	400

Table 6. HIGHWAY LOADING – 3000mm TO 6000mm DEPTH OF FILL & SURFACING - SECTION THICKNESS (mm)

		INTERNAL WIDTH (m)											
		0.5	1.0	1.5	2.0	2.5	3.0	3.5	4.0	4.5	5.0	5.5	6.0
INTERNAL HEIGHT (m)	0.5		200	200	200	200	200	250	300	350	400	400	450
	1.0	200	200	200	200	200	250	250	300	350	400	400	450
	1.5	200	200	200	200	200	250	250	300	350	400	400	450
	2.0	200	200	200	200	200	250	300	350	400	400	450	500
	2.5	200	200	200	200	200	250	300	350	400	400	450	500
	3.0	200	200	200	200	200	250	300	350	400	400	UAN	UAN

Table 7. HIGHWAY LOADING – 6000mm TO 8000mm DEPTH OF FILL & SURFACING - SECTION THICKNESS (mm)

		INTERNAL WIDTH (m)											
		0.5	1.0	1.5	2.0	2.5	3.0	3.5	4.0	4.5	5.0	5.5	6.0
INTERNAL HEIGHT (m)	0.5		200	200	200	200	250	300	350	400	400	450	500
	1.0	200	200	200	200	200	250	300	350	400	400	450	550
	1.5	200	200	200	200	250	250	300	400	400	450	500	550
	2.0	200	200	200	200	250	300	350	400	400	450	500	600
	2.5	200	200	200	200	250	300	350	400	400	450	500	600
	3.0	200	200	200	200	250	300	350	400	400	UAN	UAN	UAN

Contact our technical team for information on Standard Box Culverts which fall outside the specifications above. The above section thicknesses are recommendations. Thinner section thickness may be possible but these will correspond to increased reinforcement requirements

Standard Box Culvert Details

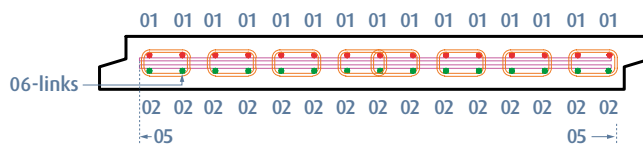
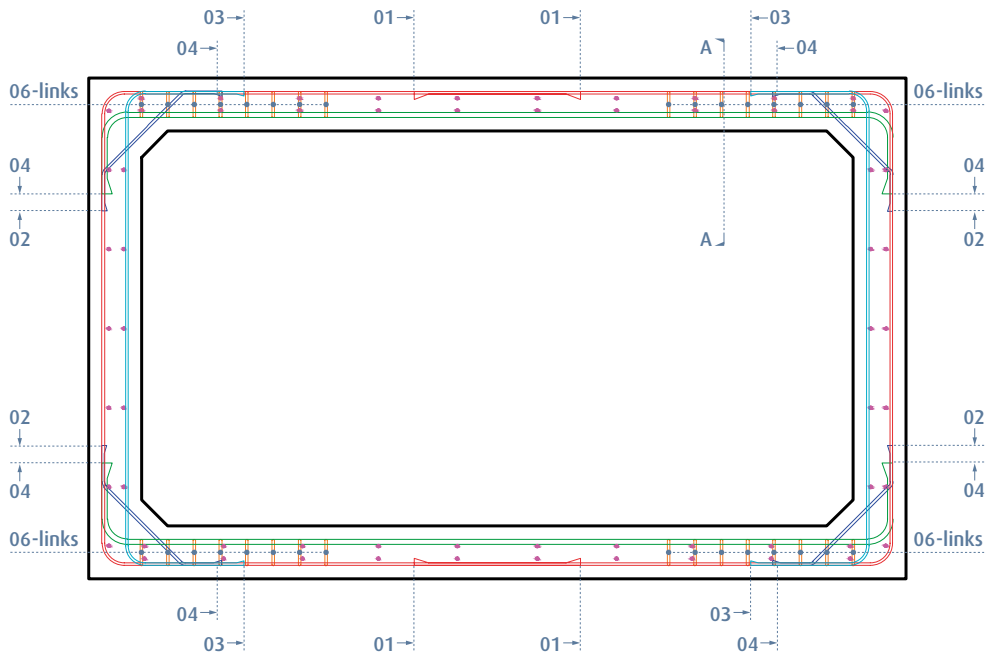
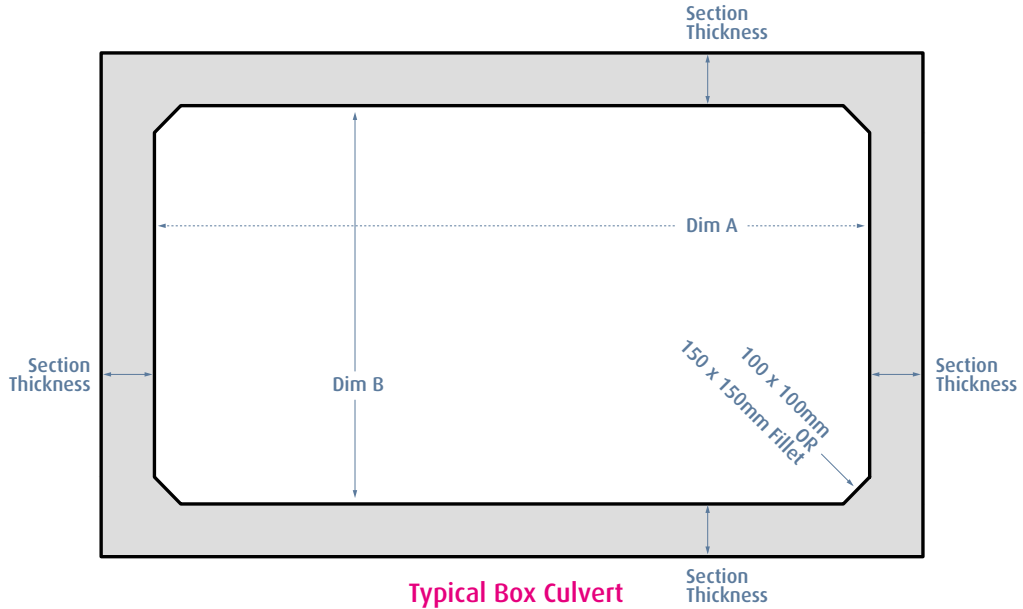

Standard UAN

Typical Applications:

Bridging watercourses, pedestrian access, vehicle access.

Advantages:

Enables large culverts to be precast and transported.

Max unit length: 2000mm

3D View of UAN

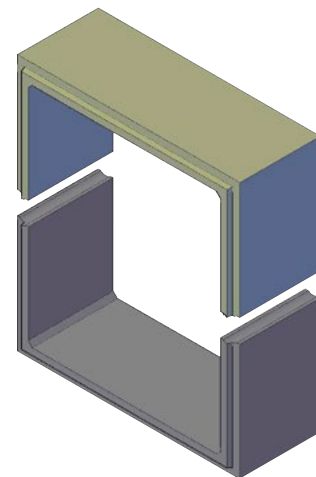

Fill Depth Tables for Standard UAN

Tables 1 to 3 below indicate the recommended UAN section thickness for units that do NOT carry highway loading based on the depth of fill above the top of the culvert.

Table 1. NO HIGHWAY LOADING - LESS THAN 3000mm DEPTH OF FILL - SECTION THICKNESS (mm)

		INTERNAL WIDTH (m)						
		3.0	3.5	4.0	4.5	5.0	5.5	6.0
INTERNAL HEIGHT (m)	3.5	200	200	250	300	350	400	400
	4.0	200	200	250	300	350	400	400
	4.5	200	200	250	300	350	400	400
	5.0	200	200	250	300	350	400	400
	5.5	200	200	250	300	350	400	400
	6.0	200	200	250	300	350	400	400

Table 2. NO HIGHWAY LOADING – 3000mm TO 6000mm DEPTH OF FILL - SECTION THICKNESS (mm)

		INTERNAL WIDTH (m)						
		3.0	3.5	4.0	4.5	5.0	5.5	6.0
INTERNAL HEIGHT (m)	3.5	250	300	400	450	550	600	650
	4.0	250	300	400	450	550	600	650
	4.5	250	300	400	450	550	600	650
	5.0	250	300	400	450	550	600	650
	5.5	250	300	400	450	550	600	650
	6.0	250	300	400	Limited	Limited	Limited	Limited

Table 3. NO HIGHWAY LOADING – 6000mm TO 8000mm DEPTH OF FILL - SECTION THICKNESS (mm)

		INTERNAL WIDTH (m)						
		3.0	3.5	4.0	4.5	5.0	5.5	6.0
INTERNAL HEIGHT (m)	3.5	300	400	400	500	600	650	750
	4.0	300	400	400	500	600	650	750
	4.5	300	400	400	500	600	650	750
	5.0	300	400	400	500	600	650	750
	5.5	300	400	400	500	600	650	Limited
	6.0	300	400	400	Limited	Limited	Limited	Limited

Tables 4 to 6 below indicate the recommended UAN section thicknesses for units that carry highway loading based on the depth of fill above the top of the N- Section.

Table 4. HIGHWAY LOADING - LESS THAN 600mm DEPTH OF FILL & SURFACING - SECTION THICKNESS (mm)

		INTERNAL WIDTH (m)						
		3.0	3.5	4.0	4.5	5.0	5.5	6.0
INTERNAL HEIGHT (m)	3.5	300	300	350	400	400	400	450
	4.0	300	300	350	400	400	400	450
	4.5	300	300	350	400	400	400	450
	5.0	300	300	350	400	400	400	450
	5.5	300	300	350	400	400	400	450
	6.0	300	300	350	400	400	400	Limited

Table 5. HIGHWAY LOADING – 600mm TO 3000mm DEPTH OF FILL & SURFACING - SECTION THICKNESS (mm)

		INTERNAL WIDTH (m)						
		3.0	3.5	4.0	4.5	5.0	5.5	6.0
INTERNAL HEIGHT (m)	3.5	300	300	350	400	450	500	600
	4.0	300	300	350	400	450	500	600
	4.5	300	300	350	400	450	500	600
	5.0	300	300	350	400	450	500	600
	5.5	300	300	350	400	450	500	600
	6.0	300	300	350	400	Limited	Limited	Limited

Table 6. HIGHWAY LOADING – 3000mm TO 6000mm DEPTH OF FILL & SURFACING - SECTION THICKNESS (mm)

		INTERNAL WIDTH (m)						
		3.0	3.5	4.0	4.5	5.0	5.5	6.0
INTERNAL HEIGHT (m)	3.5	300	350	400	450	500	600	700
	4.0	300	350	400	450	500	600	700
	4.5	300	350	400	450	500	600	700
	5.0	300	350	400	450	500	600	700
	5.5	300	350	400	450	500	600	700
	6.0	300	350	400	Limited	Limited	Limited	Limited

Table 7. HIGHWAY LOADING - 6000MM TO 8000MM DEPTH OF FILL & SURFACING - WALL THICKNESS (mm)

		INTERNAL WIDTH (m)						
		3.0	3.5	4.0	4.5	5.0	5.5	6.0
INTERNAL HEIGHT (m)	3.5	300	400	400	500	600	650	750
	4.0	300	400	400	500	600	650	750
	4.5	300	400	400	500	600	650	750
	5.0	300	400	400	500	600	650	750
	5.5	300	400	400	500	600	650	Limited
	6.0	300	400	400	Limited	Limited	Limited	Limited

Contact our technical team for information on Standard UANs which fall outside the specifications above. The above section thicknesses are recommendations. Thinner section thickness may be possible but these will correspond to increased reinforcement requirements.

Standard UAN Details

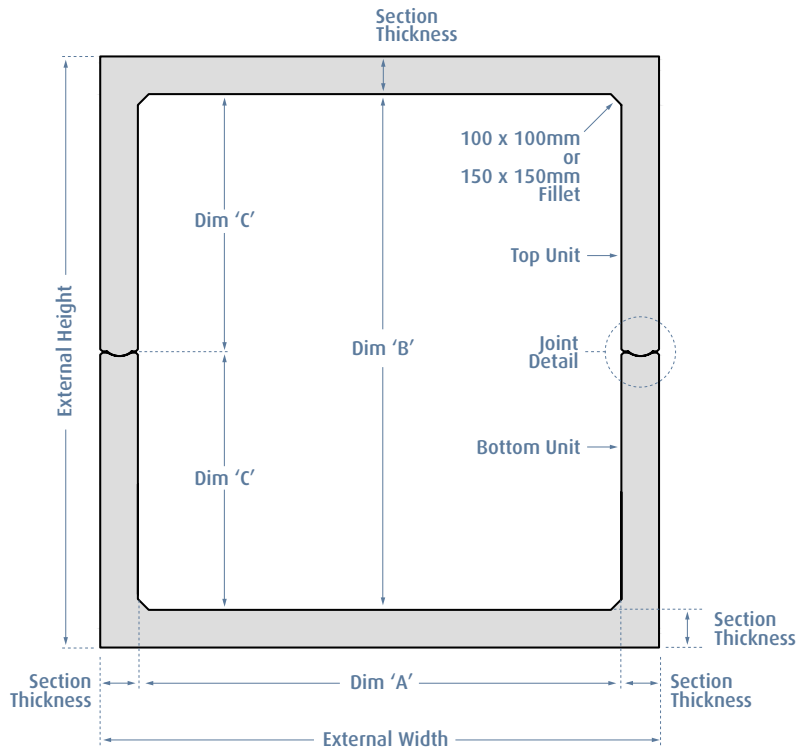

UAN Cross Section

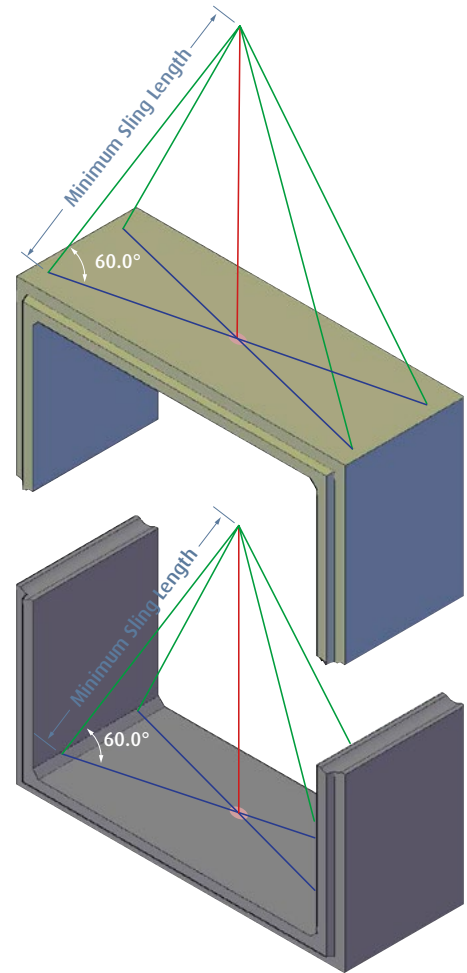

3D view of lifting drawing

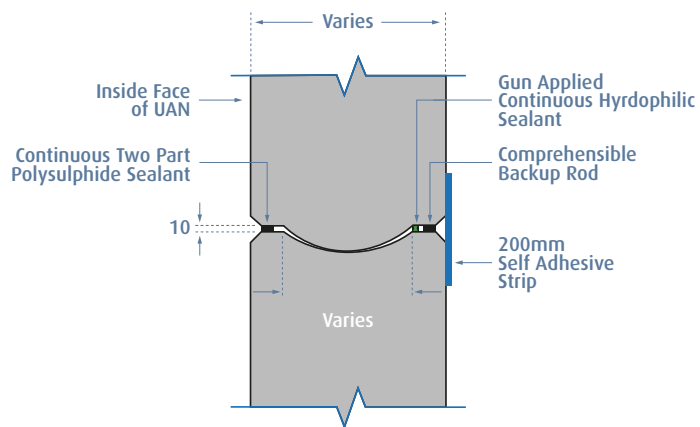

Typical Unit to Unit Joint Detail

Standard Portal

Typical Applications:

Bridging watercourses, pedestrian access, carrying services.

Advantages:

Leaves stream bed undisturbed.
Structurally efficient.

Max unit length: 2000mm

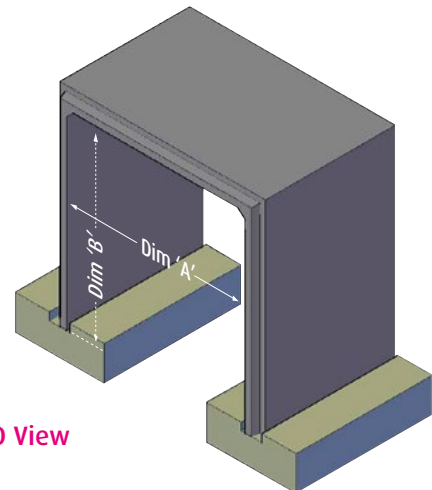

3D View

Fill Depth Tables for Standard Portal

Tables 1 to 3 below indicates the recommended portal section thickness for units that do NOT carry highway loading based on the depth of fill above the top of the culvert.

Table 1. NO HIGHWAY LOADING - LESS THAN 3000mm DEPTH OF FILL - SECTION THICKNESS (mm)

		INTERNAL WIDTH (m)															
		1.0	1.5	2.0	2.5	3.0	3.5	4.0	4.5	5.0	5.5	6.0	6.5	7.0	7.5	8.0	
INTERNAL HEIGHT (m)	0.5	200	200	200	200	200	200	200	200	200	200	250	300	300	350	400	400
	1.0	200	200	200	200	200	200	200	200	200	250	250	300	300	350	400	400
	1.5	200	200	200	200	200	200	200	200	200	250	250	300	350	350	400	400
	2.0	200	200	200	200	200	200	200	200	200	250	250	300	350	400	400	400
	2.5	200	200	200	200	200	200	200	200	250	250	300	300	350	400	400	400
	3.0	200	200	200	200	200	200	200	200	250	250	300	350	350	400	400	400

Table 2. NO HIGHWAY LOADING – 3000mm TO 6000mm DEPTH OF FILL - SECTION THICKNESS (mm)

		INTERNAL WIDTH (m)														
		1.0	1.5	2.0	2.5	3.0	3.5	4.0	4.5	5.0	5.5	6.0	6.5	7.0	7.5	8.0
INTERNAL HEIGHT (m)	0.5	200	200	200	200	200	200	250	300	300	350	400	400	450	500	550
	1.0	200	200	200	200	200	250	250	300	350	400	400	400	450	500	550
	1.5	200	200	200	200	200	250	250	300	350	400	400	450	500	550	550
	2.0	200	200	200	200	200	250	300	300	350	400	400	450	500	550	550
	2.5	200	200	200	200	200	250	300	350	400	400	400	450	550	550	600
	3.0	200	200	200	200	200	250	300	350	400	400	*	*	*	*	*

Table 3. NO HIGHWAY LOADING – 6000mm TO 8000mm DEPTH OF FILL - SECTION THICKNESS (mm)

		INTERNAL WIDTH (m)														
		1.0	1.5	2.0	2.5	3.0	3.5	4.0	4.5	5.0	5.5	6.0	6.5	7.0	7.5	8.0
INTERNAL HEIGHT (m)	0.5	200	200	200	200	200	250	300	350	400	400	450	500	550	600	650
	1.0	200	200	200	200	250	250	300	350	400	400	450	550	550	600	650
	1.5	200	200	200	200	250	300	350	400	400	450	500	550	550	650	700
	2.0	200	200	200	200	250	300	350	400	400	450	500	550	600	650	700
	2.5	200	200	200	200	250	300	350	400	400	500	550	550	600	700	700
	3.0	200	200	200	200	250	300	350	400	*	*	*	*	*	*	*

* JOINTED PORTAL

Tables 4 to 6 below indicates the recommended portal section thickness for units that carry highway loading based on the depth of fill above the top of the culvert.

Table 4. HIGHWAY LOADING – LESS THAN 600mm FILL & SURFACING - SECTION THICKNESS (mm)

		INTERNAL WIDTH (m)														
		1.0	1.5	2.0	2.5	3.0	3.5	4.0	4.5	5.0	5.5	6.0	6.5	7.0	7.5	8.0
INTERNAL HEIGHT (m)	0.5	200	200	200	200	200	200	250	250	300	300	350	350	350	400	400
	1.0	200	200	200	200	200	250	250	250	300	300	350	350	400	400	400
	1.5	200	200	200	200	250	250	250	300	300	350	350	400	400	400	400
	2.0	200	200	200	200	250	300	300	300	350	350	400	400	400	400	400
	2.5	250	250	250	250	300	300	300	350	350	400	400	400	400	400	400
	3.0	250	250	250	250	300	300	350	350	400	400	400	400	400	400	*

Table 5. HIGHWAY LOADING – 600mm TO 3000mm DEPTH OF FILL & SURFACING - SECTION THICKNESS (mm)

		INTERNAL WIDTH (m)														
		1.0	1.5	2.0	2.5	3.0	3.5	4.0	4.5	5.0	5.5	6.0	6.5	7.0	7.5	8.0
INTERNAL HEIGHT (m)	0.5	200	200	200	200	200	200	250	250	250	300	350	400	400	400	400
	1.0	200	200	200	200	200	200	250	250	300	300	350	400	400	400	450
	1.5	200	200	200	200	250	250	250	250	300	350	350	400	400	400	450
	2.0	200	200	200	200	250	250	250	300	300	350	400	400	400	450	450
	2.5	250	250	250	250	250	300	300	300	350	350	400	400	400	450	500
	3.0	250	250	250	250	300	300	300	300	350	400	400	400	400	*	*

Table 6. HIGHWAY LOADING – 3000mm TO 6000mm DEPTH OF FILL & SURFACING - SECTION THICKNESS (mm)

		INTERNAL WIDTH (m)														
		1.0	1.5	2.0	2.5	3.0	3.5	4.0	4.5	5.0	5.5	6.0	6.5	7.0	7.5	8.0
INTERNAL HEIGHT (m)	0.5	200	200	200	200	200	250	250	300	350	400	400	400	450	500	550
	1.0	200	200	200	200	200	250	250	300	350	400	400	450	500	550	550
	1.5	200	200	200	200	200	250	300	350	350	400	400	450	500	550	550
	2.0	200	200	200	200	200	250	300	350	400	400	450	500	550	550	600
	2.5	200	200	200	200	250	250	300	350	400	400	450	500	550	550	600
	3.0	200	200	200	200	250	250	300	350	400	400	*	*	*	*	*

Table 7. HIGHWAY LOADING – 6000mm TO 8000mm DEPTH OF FILL & SURFACING - SECTION THICKNESS (mm)

		INTERNAL WIDTH (m)														
		1.0	1.5	2.0	2.5	3.0	3.5	4.0	4.5	5.0	5.5	6.0	6.5	7.0	7.5	8.0
INTERNAL HEIGHT (m)	0.5	200	200	200	200	200	250	300	350	400	400	450	500	550	600	650
	1.0	200	200	200	200	250	250	300	350	400	400	450	550	550	600	650
	1.5	200	200	200	200	250	300	350	400	400	450	500	550	550	650	700
	2.0	200	200	200	200	250	300	350	400	400	450	500	550	600	650	700
	2.5	200	200	200	200	250	300	350	400	400	500	550	550	600	700	700
	3.0	200	200	200	200	250	300	350	400	*	*	*	*	*	*	*

* JOINTED PORTAL

Contact our technical team for information on Standard Portals which fall outside the specifications above. The above section thicknesses are recommendations. Thinner section thickness may be possible but these will correspond to increased reinforcement requirements.

Standard Portal Details

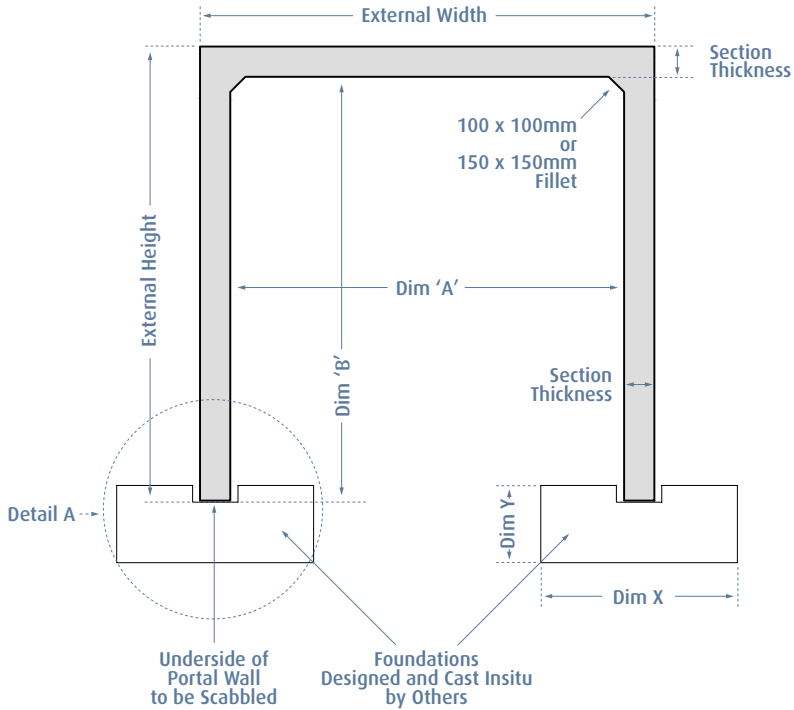

Typical Portal Section

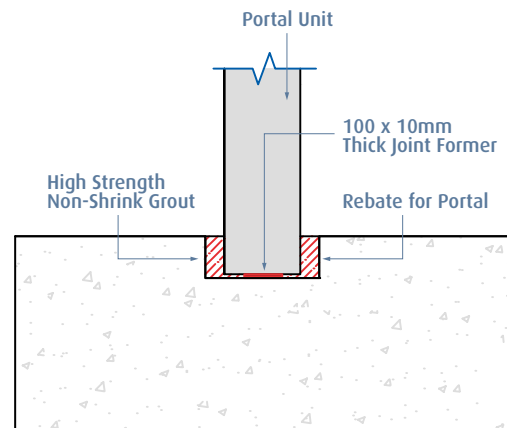

Detail A

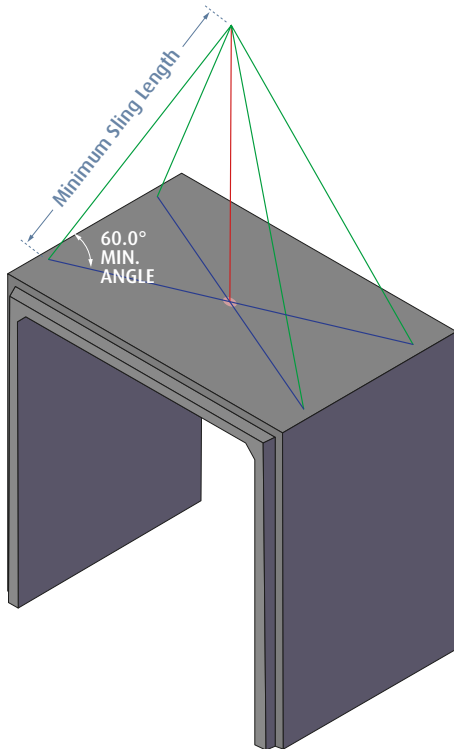

Typical lifting arrangement

Other Structural Types

Jointed Portal

Portals can be manufactured in a number of configurations depending on the dimensions of the unit required. For larger units, because of transport limitations, we manufacture them in segments as shown on the right. These portals are usually used for bridging.

Jointed Portals can be manufactured in sizes up to 15000mm x 9000mm (Dim 'A' x Dim 'B'). For spans larger than this it is often more economical to use pre-stressed beams.

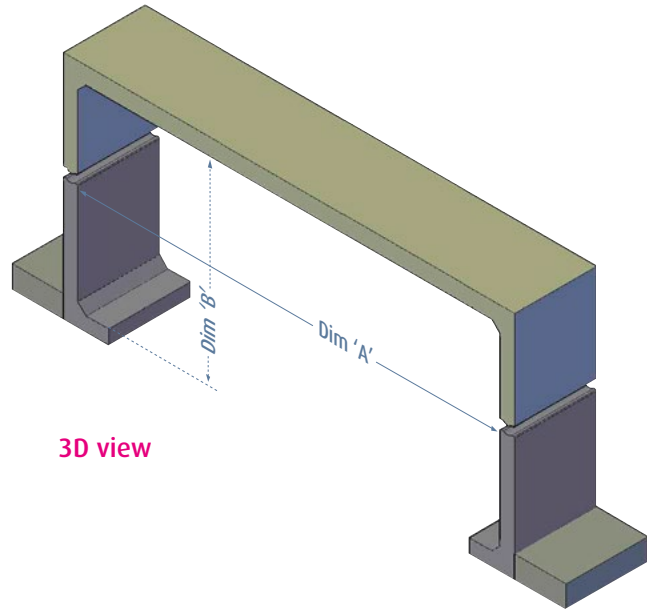

3D view

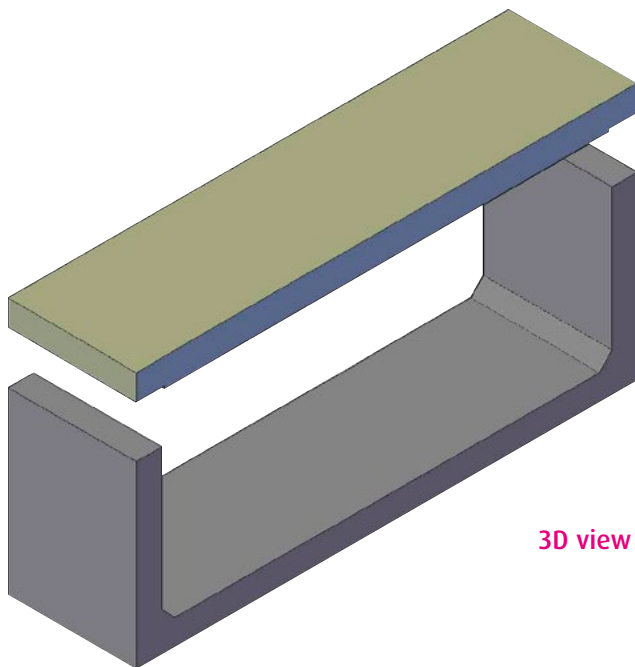

3D view

U - Section with Lid

The use of a U-Section and lid provides future access to the culvert run after it has been installed. This ease of access facilitates the addition of stream bed material and cleaning after installation. Depending on specific site requirements, dowel holes or cast in sockets can be provided in the U-Section and lid in order to fix the lid with provision for future removal if required.

Skewed & Splayed Culverts

Typically used when a box culvert line changes direction.

Max unit Length: 2000mm*

Min Unit Length: 800mm

Splay Angle Range: A range of angles can be achieved by using multiple splayed units as required.

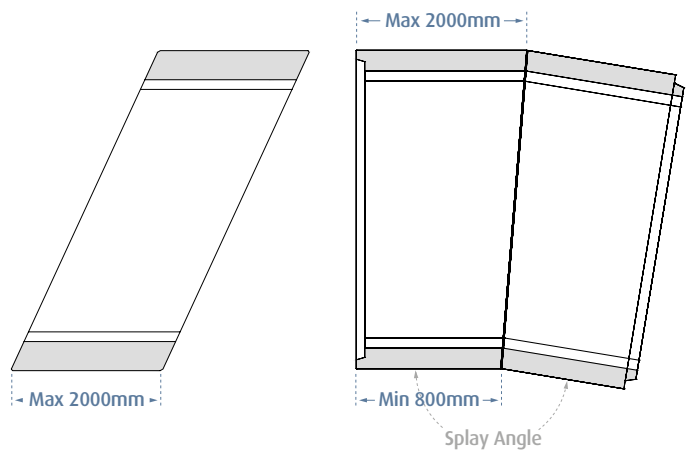

Skewed Culvert

Splayed Culvert

Note: Please contact our technical team for more information on skewed culverts.

Attenuation Tank

Box culverts can be used to make a cost effective, easily installed attenuation tank with a large volume. Attenuation tanks are used as a flood mitigation system for dealing with excess surface water runoff. It operates by retaining water on site, - then slowly releasing it in a controlled discharge to a drain, water source or sewer.

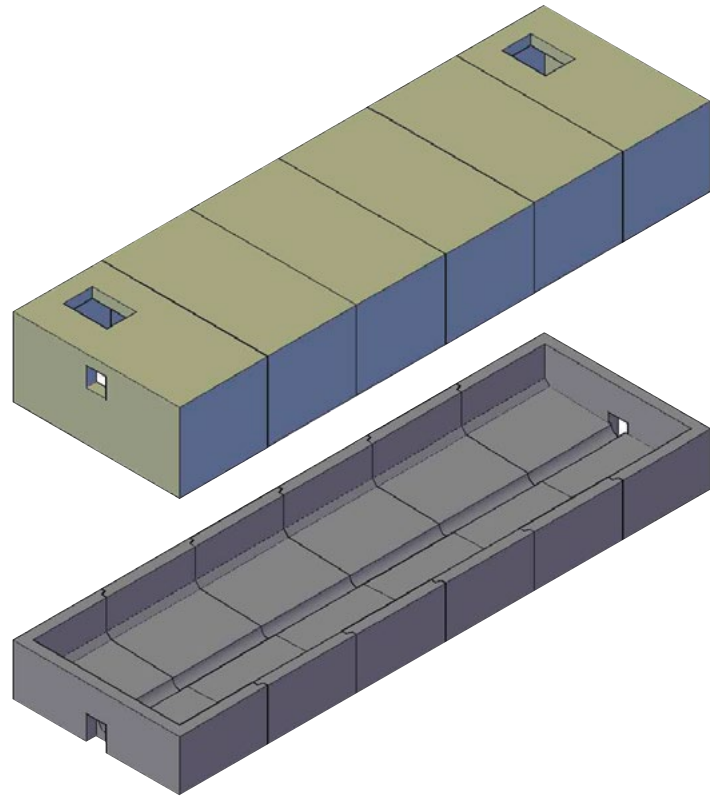

3D View including flow channel

Double Cell

Double cell box culverts allow for the separate flow of water, which is suitable when headroom is restricted and design flow needs to be high. One invert can be designed at a lower level to cater for low flow conditions if required, thus reducing the occurrence of sediment deposition. Flow can easily be diverted from one cell to another to facilitate the maintenance of each cell.

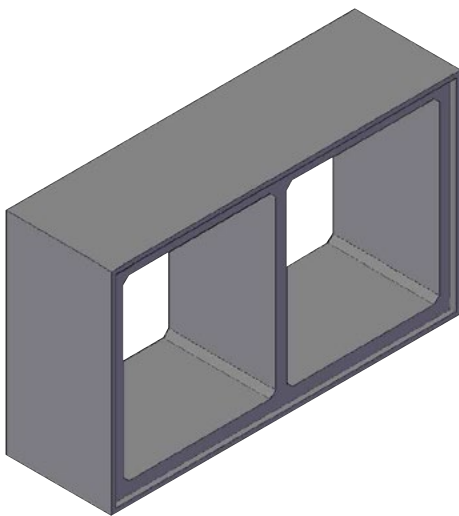

3D view

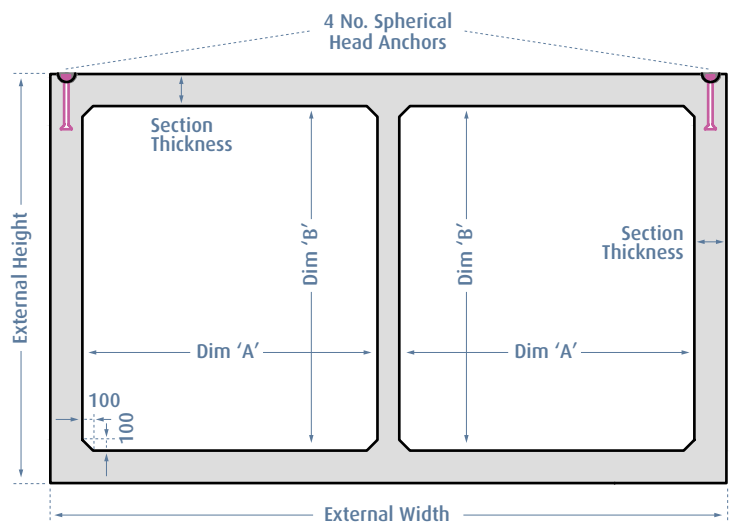

Typical Double Cell Cross Section

Additional Details Associated with Box Culverts

All of our box culverts can be designed with a number of different additional features depending on their intended purpose. A combination of multiple features is also possible.

Mammal Shelf

A mammal shelf can be used as a substitute for costly onsite provisions when the watercourse forms the natural passage way from one side of the road to the other. They can be cast as solid blocks or as a cantilever.

All mammal shelves should be at least 500mm wide and must be accessible at both ends of the bank and from the water. The shelf should clear the 5 year flood level by at least 150mm and have a minimum 600mm of headroom.

When a mammal shelf is to be installed for a species such as otters, it is important to carry out a survey to identify their preferred bank for travelling. By installing the shelf on their preferred side, any disturbance is kept to a minimum.

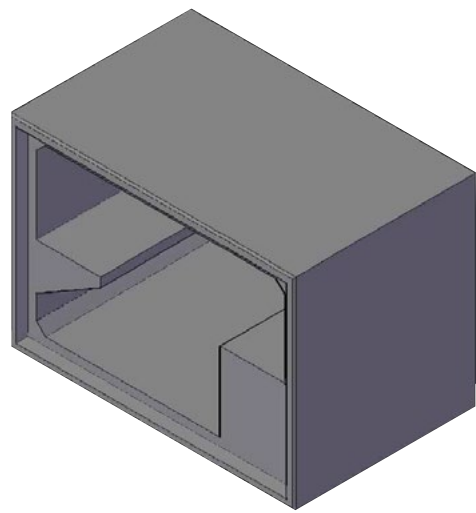

3D view

Dry Weather Flow (D.W.F) Channel

A DWF channel consist of a tapered invert with a semicircular channel.

The benefits include an improved flow rate and lower maintenance due to increased self cleansing properties.

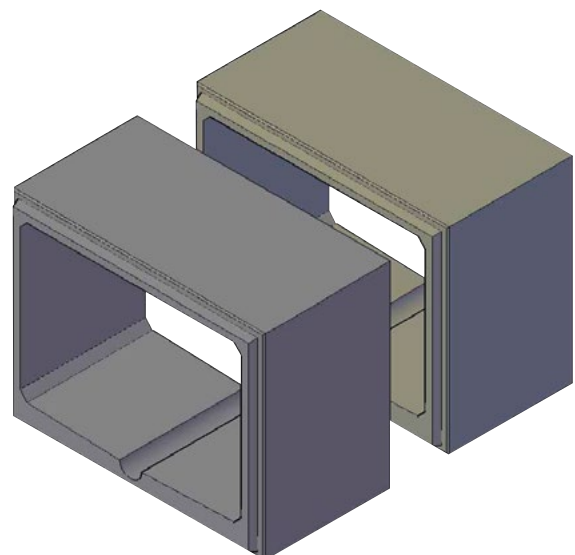

3D view

Fish Control

Where a culvert is intended to guide the passage of fish, special provisions must be made. The minimum span of such a culvert is 900mm and it should be oversized such that it can be set at least 500mm below the bed level, in order to allow natural sediment to form the bed of the channel.

The culvert should be installed so that it has a constant slope throughout its length and is at a level and grade which allows the upstream invert to remain drowned (by back watering) under low flow conditions to a depth which allows the largest species frequenting the stream to pass.

The effective slope of the culvert should generally not exceed:

- 0.5% for a culvert greater than 24m in length, unless baffles are added;
- 1.0% for a culvert less than 24m in length, unless baffles are added;
- 5.0% at any time, even with the addition of baffles 3D View
- Where >5.0%, site specific design will be required.

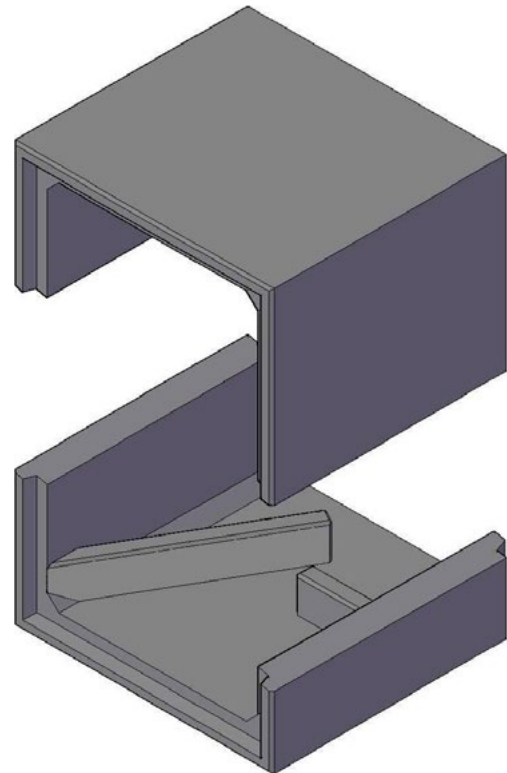

3D view

In situations where a culvert has to be laid at a steep gradient, baffles should be laid so as to provide a low-flow channel along the central axis and to reduce the velocity of flow, allowing fish to swim upstream without undue effort.

Culverts with discharges below three times the average daily flow should be designed such that the water velocity does not exceed the following values:

- 1.2m/s for culverts less than 24m in length,
- 0.9m/s for culverts greater than 24m in length.

It should be noted that culverts greater than 60m in length would need special consideration for fish passage, such as light-openings, in order to avoid sharp light/dark interfaces. A culvert with a depressed channel filled with gravel can also facilitate fish passage.

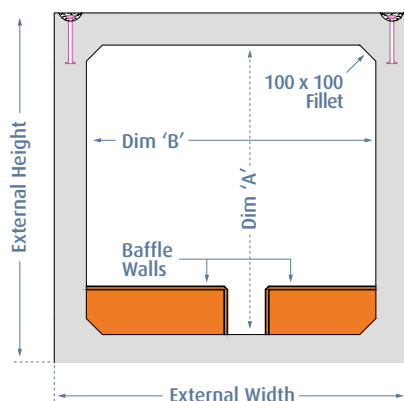

Baffle Walls for Fish Pass (Section)

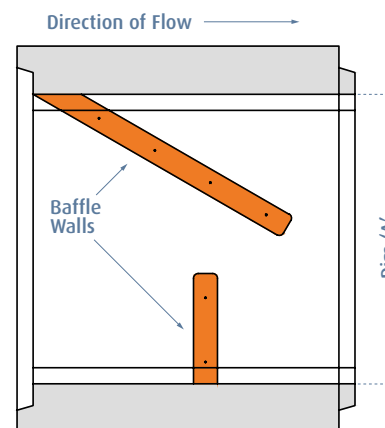

Baffle Walls for Fish Pass (Plan)

Wing Walls and Head Beams

A wing wall and head beam combination holds back soil and sediment like a retaining wall, preventing the watercourse from becoming blocked. They also protect the embankment from erosion by channelling water into the culvert path.

Shay Murtagh Precast can manufacture wing walls with a number of features such as overhangs and splays in order to suit whatever hydraulic profile is required. In-situ stitch details required for larger units can also be accommodated.

Head beams are usually cast as separate units that are connected to the end culvert units and are jointed using a dowel detail. Wing walls are jointed to the face of the culvert using a flexible joint with typically a two part polysulphide sealant.

Note: All wing wall units require a toe and larger units will require a heel, the dimensions of which vary from project to project. As the wing walls are often the largest units, it is important to wait until the design of these is received from Shay Murtagh Precast before making any lifting arrangements.

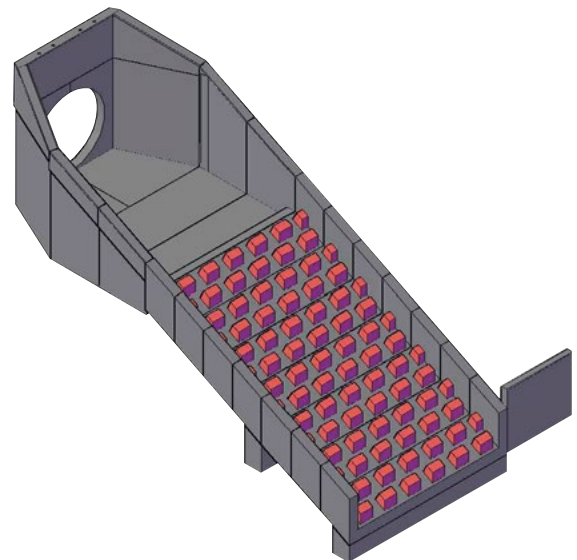
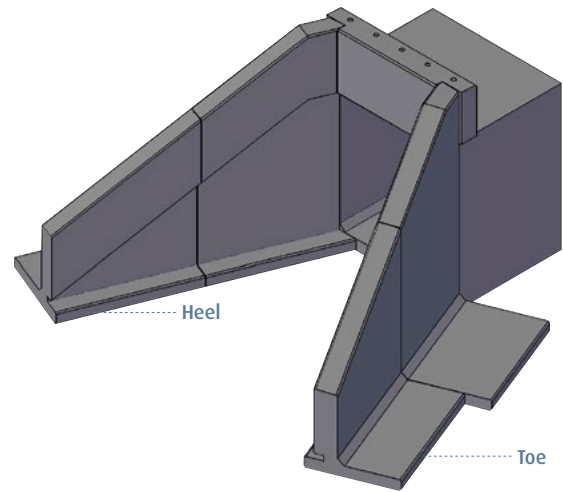

Bespoke Drainage Outfall

Drainage Outfall

Shay Murtagh Precast can manufacture a range of drainage outfalls incorporating a variety of features, including baffle blocks, stilling basins and scour protection.

We can manufacture drainage outfalls with opening diameters ranging from 400mm to 2400mm.

Screens can also be accommodated, designed and detailed to specific client requirements.

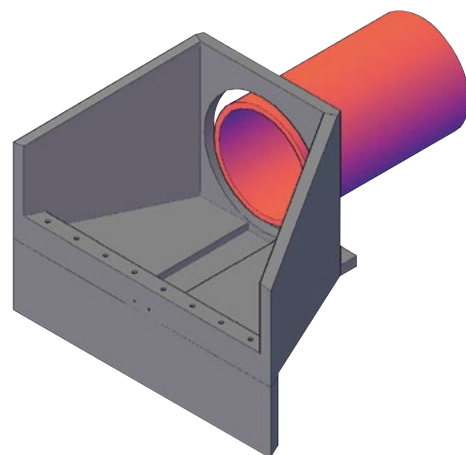

Standard Drainage Outfall

Guide to Site Practice - Box Culverts

Taking Delivery

When preparing to take delivery of the box culverts the contractor should supply Shay Murtagh Precast with:

- Site contact details – name, e-mail address and phone number;
- An exact site address, including postcode and GPS coordinates if available;
- Any delivery constraints such as access times and specific entrance routes.

(It is the responsibility of the contractor to offload the culverts on site.)

Normally, box culverts are transported as laid, however they are sometimes transported on end for safety reasons and due to transport restrictions. When box culverts are transported on end, they will require a safe system for offloading. In this situation Shay Murtagh Precast will provide a data sheet and specific lifting details prior to the first delivery to guide the lifting process.

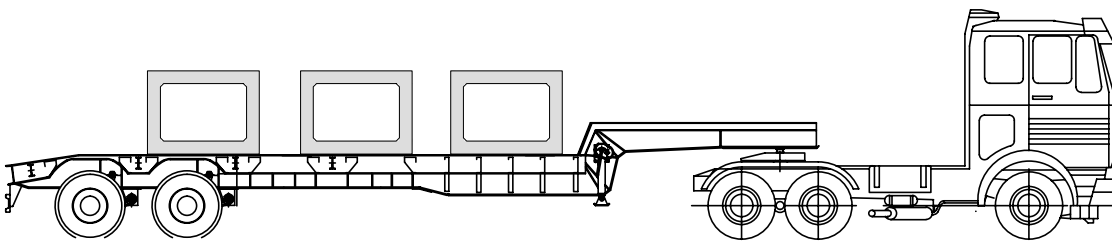

Shay Murtagh Precast uses spherical head anchor lifters as standard for the lifting arrangements of culverts, portal frames etc.

Note: It is the contractor's responsibility to provide all necessary lifting equipment on site. Please contact Shay Murtagh Precast technical department for rates on the supply of lifting shackles and associated certificates.

Box culverts must be offloaded by means of a suitable crane and stored on a firm level base. They can be stored in line with the culvert trench, but must be kept away from its edge. In order to prevent damage, it is important to move the culverts by lifting and never by dragging.



Lifting Guide/Arrangement

Culvert units should always be lifted level. A drawing showing minimum sling lengths will always be provided by Shay Murtagh Precast.

Note: The sling lengths may be adjusted on site by the contractor to enable level lifting of units. The angle of the sling should always be greater than or equal to 60° and less than or equal to 90°. (Refer to standard lifting manuals provided by spherical head anchor manufacturers for further details).

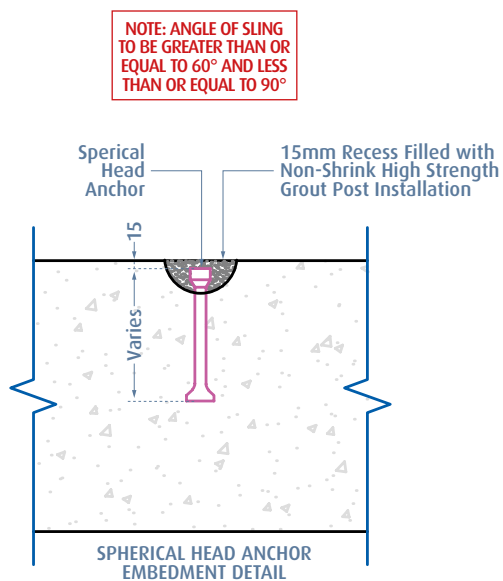

Standard Lifter Detail

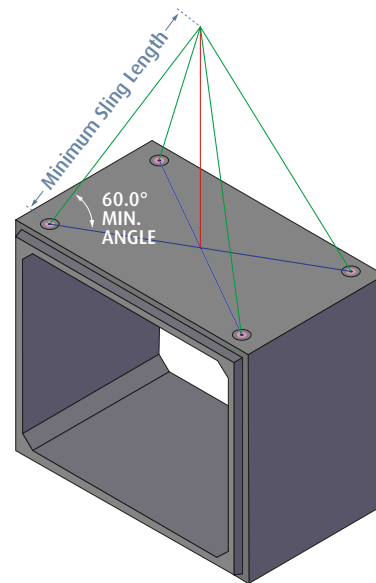

Standard Lifting Arrangement

Preparing the Trench

When excavating the trench its width should be such that the culverts can be safely installed with an allowance for compaction of backfill to the box side while avoiding unnecessary excavation and backfill.

- Carefully trim the formation to the required depth and gradient, allowing for the thickness of the bedding.
- Remove local hard or soft areas and bring to level with well compacted granular material.

Bedding

The bedding ensures a level, uniform base, allowing full load bearing capacity to be achieved.

The bedding consists of either granular material or blinding concrete with adequate thickness and good levelling. The recommended values for the thickness are (See BS EN 14844:2006 Annex C):

- Granular Bedding 150mm to 200mm
- Concrete Bedding 70mm to 100mm

When concrete bedding is used, a layer of fine material should be provided to enable levelling of the units and to avoid direct contact between the concrete surfaces.

The specified line and gradient should be built into the bedding.

In order to prevent the bedding from deteriorating, the contractor should:

- Lay the bedding only a minimum distance ahead of the laying of box culverts.
- Keep off the prepared base so far as it is practical.
- Avoid local packing, which are subject to settlement.

Sometimes it is more appropriate to use an alternative form of foundation e.g. piled ground beams or reinforced concrete. In such cases the contractor should inform Shay Murtagh Precast of the foundation to be used as this alters the support conditions for the culvert which needs to be accounted for in our design calculations.

Laying the Culverts & Jointing

A box culvert run is normally laid from downstream to upstream, with the sockets facing upstream ready to receive the next culvert.

- Inspect each culvert unit before laying.
- Carefully lower each unit into the prepared trench, ensuring the spigot of the unit to be installed and the socket of the receiving unit are aligned correctly.
- Prevent loose surface bedding material from entering the joint space during positioning of the unit.
- If any adjustment to level is necessary, remove the box culvert and adjust the surface level of the bedding.
Do not use local packing to adjust the level.
- Shay Murtagh Precast recommends the use of proprietary jointing material applied in accordance with the Manufacturer's specific instructions in terms of application and substrate preparation.
- A hydrophilic strip is gun applied at the central section of the spigot socket joint prior to the upstream unit being slotted uniformly into place. Care must be taken to ensure full and uniform application along all joint edges.
- A one part polyurethane sealant is applied to all internal edges of a culvert joint. A 200mm wide flexible self adhesive water proofing strip applied to the outer edges of the joint on the top and vertical faces. Shay Murtagh Precast recommends the use of a protective board or non woven geotextile at the back of the flexible self adhesive proofing strip to protect the joint.
- Accumulation of water in the trench should be avoided by diverting the watercourse and by pumping water from the trench.
- Further advice and product data sheets are available on request from Shay Murtagh Precast or directly from the specific material manufacturers.

Where applicable, the precast identification label supplied by Shay Murtagh Precast will reference the unit type and number based on the manufacturing sequence or units. Note that it is the responsibility of the installation team/main contractor to record the as built installation order of the precast units.

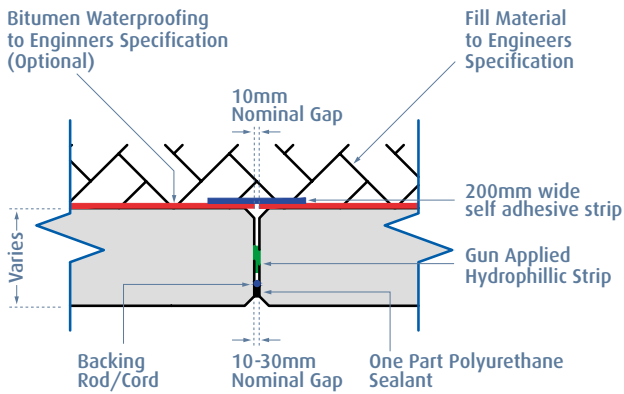

Typical Flat Joint Detail

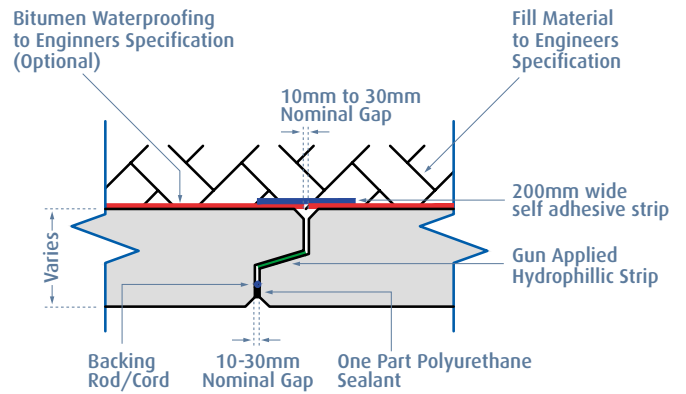

Typical Standard Jointing Detail

Shay Murtagh Precast can if requested, supply jointing material contact sales@shaymurtagh.ie for a quotation and further information.

Backfilling

- Backfilling should commence as soon as possible after the box culverts have been laid.
- The trench should be filled to the level of the top of the box culvert, working alternatively on both sides, using selected granular materials, compacted in layers not exceeding 200mm and maintaining a different level on each side of the culvert of not more than 500mm.
- Initial backfill over the box culvert should also be carried out in 200mm layers of granular material.
- Frozen or organic materials are not suitable for backfilling.
- Loads from construction plant in minimum fill conditions may require seperate design considerations and should be checked with Shay Murtagh precast prior to implementation.

Care must be taken since site traffic and construction equipment over shallow fill depths can impose loadings greater than those for which the finished box culvert has been designed. In such cases, contact the technical team at Shay Murtagh Precast.



DESIGNER'S CHECKLIST: DESIGN NOTES

CONCRETE

Our standard concrete mixes have been designed to attain a 28 day strength of C50/60. Other concrete strengths can be considered.

FINISHES

All internal and external faces of box culvert units will have a formed finish. Colour variations may occur between our units and any in-situ works.

CAST IN ITEMS

Cast in items can be included providing that they do not project through the sides or soffit of our standard moulds. Care should be taken to ensure that any cast in items do not conflict with reinforcement locations.

LIFTING

Our standard lifting methods are shown, however methods vary due to unit size and specific site requirements.

LENGTHS

The maximum length of standard culvert units are 2.0m. The overall length must include the extents of the unit and any skew that is being provided.

In some instances we may offer 2.5m long units, however as these are non-standard units it is advisable to contact our Technical Department for more information and confirm availability.

TOLERANCES

Tolerances should be to either the relevant Highways Specification or the Eurocodes.

HANDLING

Shay Murtagh Precast carries out detailed lifting calculations for each individual unit and provides general arrangement and lifting details as standard. This provides the necessary information to allow our clients to plan handling, temporary works and optimise crange.

ASSUMPTIONS AND DESIGN CRITERIA USED FOR THE SECTION THICKNESS TABLES

The Eurocodes are used in conjunction with the relevant UK and Irish National Annexes Road vehicle live loading is applied using load models LM1, LM2 and the applicable range of LM3 vehicles (SV vehicles only) as per EN 1991-2:2003, the UK and Irish National Annexes to the same, and PD 6694-1:2011. Please contact our technical team to discuss section thickness reductions for special cases.

RAIL APPLICATIONS

The section thickness tables provided are not applicable for rail loading. Please contact the Shay Murtagh Precast technical department for assistance with selecting the most suitable type and size of unit; indicate the following details:

- Depth of ballast above the deck.
- Type of rail loading to be considered (Typically LM71).

DESIGNER'S CHECKLIST: DESIGN NOTES

Considerations to Irish NA to EN 1992-2:2005

Increased section thicknesses may be required for culverts in Ireland with deep fill where XD or XS exposure classes are specified due to the onerous crack width limits specified by the Irish National Annex to EN 1992-2:2005 (a departure from standard is strongly recommended).

Stages in Box Culvert Design

The typical stages involved in the design of a precast concrete box culvert are as follows:

ASSESS PURPOSE OF CULVERT:

- Hydraulic requirements (internal dimensions)
- Culvert usage
- Length required
- Wing wall extent and layout

ASSESS SITE CONDITIONS

- Depths of fill (minimum and maximum)
- Live loading conditions
- Exposure classes to BS 8500 and BS EN 206
- Culvert formation ground conditions and bearing capacity/allowable bearing pressure
- Lifting weight constraints

STRUCTURAL DESIGN

- Contact Shay Murtagh Precast with the above information
- Shay Murtagh Precast carries out the detailed structural design of the box culvert and associated structural elements

APPROVAL OF DESIGN

- Keep in contact with Shay Murtagh Precast and provide design feedback
- Once satisfied, approve the design for manufacture
- Make preparations for the delivery and installation of the box culvert

For consultation with our Design Team please contact:

technical@shaymurtagh.co.uk

or

UK Tel: 0844 202 0263

IRL Tel: +353 44 9374108 / 9374149



Although Shay Murtagh Precast Limited does its best to ensure that any advice, recommendations or information it may give is accurate, no liability or responsibility of any kind (including liability for negligence) is accepted by Shay Murtagh Precast Limited, its staff or agents. Claims and statements made by Shay Murtagh Precast Limited regarding its products refer to those which have been properly handled on site. Shay Murtagh Precast Limited cannot accept any liability or responsibility of any kind including liability for negligence for problems caused by the acts or omissions of third parties or by poor site practices.



**SHAY
MURTAGH**

Shay Murtagh Limited
 Raharney, Mullingar
 Co. Westmeath, Ireland.
 IR Tel: 353-44-9374108/9374149
 IR Fax: 353-44-9374552
 Website: www.shaymurtagh.ie
 Email: sales@shaymurtagh.ie

UK Tel: 0844 202 0263
 Website: www.shaymurtagh.co.uk
 Email: sales@shaymurtagh.co.uk

